

Grundfos Pressure Manager

PM 1 and PM 2
50/60 Hz



Contents

General description

Introduction	3
Features	3

Product range

PM 1	5
PM 2	5

Applications

Liquids	6
Examples of applications	6

Installation

Mechanical installation	8
Electrical installation	8

Functions

PM 1	9
PM 2	9

Selection

Selection of Pressure Manager	10
Selection of pressure tank	10
Grundfos pumps used with PM 1 and PM 2	11
Replacement	11
Replacement chart	12

Technical data

Technical data	13
Dimensions	13
Pressure loss curves	13

Approvals and markings

Electrical approvals	14
Other approvals and compliance with directives	14
Drinking water approvals	14
Product marks	14

Further product documentation

WebCAPS	15
WinCAPS	16

Introduction



TM04 0333 0508 - TM04 0334 0508

Fig. 1 Grundfos PM 1 and PM 2

The Grundfos PM 1 and PM 2 pressure managers are designed for automatic start/stop control of Grundfos pumps and other water supply pumps.

PM 1

The PM 1 is suitable for applications where start/stop of the pump according to consumption is needed. It is the basic control solution offering start at 1.5 or 2.2 bar. The PM 1 starts the pump when the start pressure is reached, and the pump keeps running as long as there is a flow.

The PM 1 offers dry-running protection and cycling alarm for increased safety.

PM 2

The PM 2 is the all-round control solution offering adjustable start at 1.5 to 5 bar. This enables customisation to different types of installations and desired comfort level.

The start pressure is set by means of DIP switches located behind the control panel whereas the current pressure is indicated on the LED display on the front of the PM 2.

The PM 2 starts the pump when the start pressure is reached, and the pump keeps running as long as there is a flow.

The PM 2 can be optimised for operation with an external pressure tank by enabling the 1 bar differential-pressure function. This function significantly reduces the number of operating hours of the pump in installations with pressure tank.

Features

The table below gives a brief comparison of the features of the PM 1 and PM 2. The main features are described beneath the table.

Model	PM 1	PM 2
Power-on indication	•	•
Pump running indication	•	•
Alarm indication	•	•
Dry-running protection	•	•
Free position in installation	•	•
Suitable for generator supply	•	•
Rotary outlet connection	•	•
Integrated non-return valve	•	•
Cycling alarm	•	•
Integrated pressure sensor from Grundfos Direct Sensors™		•
Adjustable start pressure		•
Start/stop with 1 bar differential pressure		•
Automatic restarting after dry running		•
Maximum continuous operating time (30 minutes) (safety)		•
Pressure indication		•
Internal pressure tank		•

User-friendly interface

The PM 1 and PM 2 have a user-friendly interface with LED indicators showing:

- power on
- pump running
- alarm indication
- pressure indication (only PM 2).

Free position in installation

The PM 1 and PM 2 can be freely positioned in the installation – vertically, horizontally, or at an angle. This makes it easier to install the units in confined spaces and in extensive existing pipework.



TM04 4913 2209

Fig. 2 Free positioning of the PM 1 and PM 2

The control panel of the PM 2 can be turned 360 ° in steps of 90 °. It is thus possible to change the orientation of the control panel depending on the mounting position. See fig. 3.

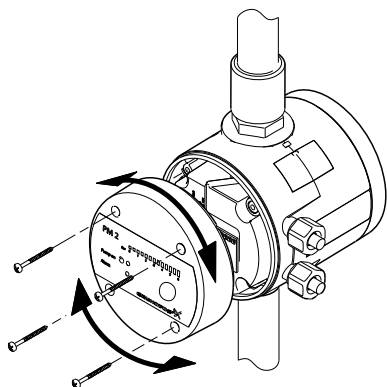

Fig. 3 Orientation of the control panel

TM04 1951 1508

Flexible power supply

Due to robust electronic components, the PM 1 and PM 2 can be powered by a generator or other alternative power supplies.

Rotary outlet connection

The outlet connection of the PM units can be rotated 360 °. See fig. 4.

The inlet connection is an integrated part of the unit housing.

The units have a built-in non-return valve.

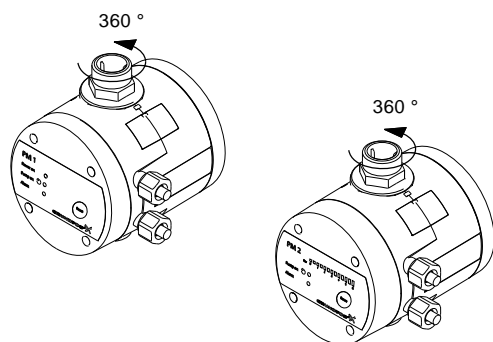

Fig. 4 Rotary outlet connections

TM03 9706 1708 - TM03 9707 1508

Protective functions

The PM 1 and PM 2 incorporate a number of functions which protect both the pump and the installation.

Protective functions:

- dry-running protection
- cycling alarm
- maximum continuous operating time (30 minutes) (PM 2 only)

The PM 2 has an auto-reset function which can be used to automatically restart the pump.

For further information, see section *Functions* on page 9.

Adaptability

The PM 2 can be adapted to the individual installation. Via a number of DIP switches located behind the control panel, the start pressure can be adjusted from 1.5 to 5 bar. Furthermore, the PM 2 can be set to an operating mode with 1 bar differential pressure between start and stop of the pump. This operating mode is intended for systems with an external pressure tank.

For further information, see section *Functions* on page 9.

Internal pressure tank (PM 2)

The PM 2 incorporates a small internal pressure tank which minimises the number of starts and stops of the pump in case of minor leakages.

PM 1

1 x 220-240 V, 50/60 Hz

Start pressure [bar]	Plug type	Socket type	Max. liquid temperature [°C]	Max. ambient temperature [°C]	Cable length [m]		Product number
					Mains	Motor	
1.5	–	–	40	50	–	–	96848670
1.5	Schuko	Schuko	40	50	1.5	0.48	96848693
1.5	Australia	–	40	50	1.5	0.48	96848694
1.5	CH	CH	40	50	1.5	0.48	96848700
1.5	–	–	60	55	–	–	96848699*
2.2	–	–	40	50	–	–	96848701
2.2	Schuko	Schuko	40	50	1.5	0.48	96848722
2.2	Australia	–	40	50	1.5	0.48	96848723
2.2	CH	CH	40	50	1.5	0.48	96848728
2.2	–	–	60	55	–	–	96848725*

* Variant intended for installation in warm climates. This variant has no VDE approval.

1 x 110-120 V, 50/60 Hz

Start pressure [bar]	Plug type	Socket type	Max. liquid temperature [°C]	Max. ambient temperature [°C]	Cable length [m]		Product number
					Mains	Motor	
1.5	–	–	40	50	–	–	96848730
2.2	–	–	40	50	–	–	96848732

PM 2

1 x 220-240 V, 50/60 Hz

Start pressure* [bar]	Plug type	Socket type	Max. liquid temperature [°C]	Max. ambient temperature [°C]	Cable length [m]		Product number
					Mains	Motor	
1.5 - 5	–	–	40	50	–	–	96848738
1.5 - 5	Schuko	Schuko	40	50	1.5	0.48	96848740
1.5 - 5	Australia	–	40	50	1.5	0.48	96848744
1.5 - 5	CH	CH	40	50	1.5	0.48	96848748
1.5 - 5	–	–	60	55	–	–	96848746**

* The start pressure can be set from 1.5 to 5.0 bar in steps of 0.5 bar.

** Variant intended for installation in warm climates. This variant has no VDE approval.

1 x 110-120 V, 50/60 Hz

Start pressure* [bar]	Plug type	Socket type	Max. liquid temperature [°C]	Max. ambient temperature [°C]	Cable length [m]		Product number
					Mains	Motor	
1.5 - 5	–	–	40	50	–	–	96848750

* The start pressure can be set from 1.5 to 5.0 bar in steps of 0.5 bar.

Typical applications are water supply systems and rainwater systems in

- single-family houses
- blocks of flats
- summer houses and holiday cottages
- horticulture and gardening
- agriculture.

Liquids

Clean, thin, non-aggressive and non-explosive liquids without solid particles or fibres that may attack the unit mechanically or chemically.

Examples:

- municipal water
- rainwater.

Examples of applications

PM 1 or PM 2 installed in connection with an SQ pump

When the PM unit is installed downstream from the pressure tank, the SQ pump is started immediately when a tap is opened. This means that the pump is started when there is a flow. In this way the pressure tank compensates for the pressure drop to be expected when the pump starts. The pump takes a few seconds to reach full speed, i.e. pressure.

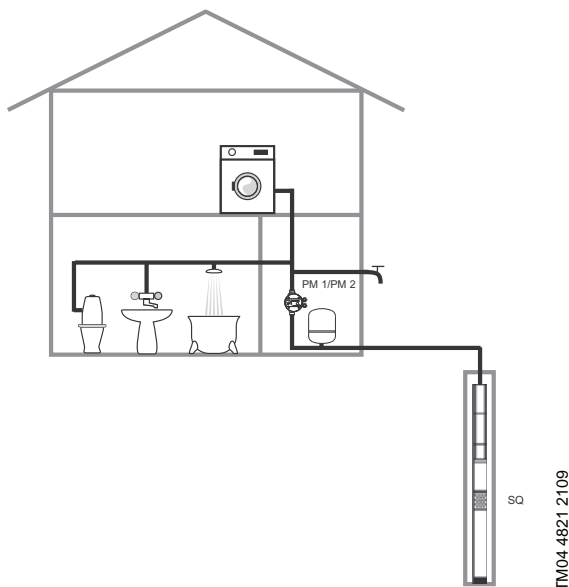

Fig. 5 Water supply from a borehole – typically at depths exceeding 8 metres

PM 1 or PM 2 installed in connection with a JP pump

The PM unit and the JP pump constitute a small waterworks. The pump will be started whenever water is consumed, due to the pressure drop. If the water level in the well drops from time to time, the pump may run dry. In this case, the PM 2 can be used with the auto-reset function enabled. Then the water supply will automatically be re-established when the water level rises again, and the pump is thus able to reprime the suction line.

Note: The same function can be achieved if the pump is drawing water from a break tank as long as the pump is able to self-prime.

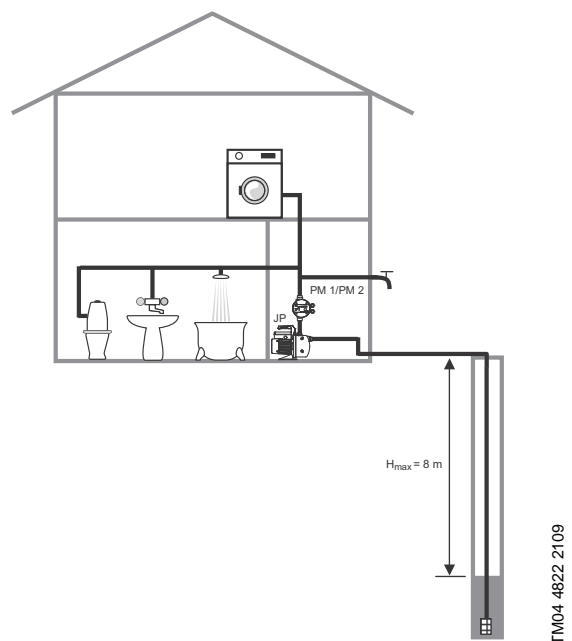

Fig. 6 Water supply from a well – typically at depths down to 8 metres

PM 1 or PM 2 installed in connection with a CH pump

If the pump inlet pressure exceeds the start pressure of the PM unit, the pump will be started due to flow when water is consumed, i.e. the PM units will still start the pump when water is consumed even though the pump inlet pressure is higher than the start pressure of the unit.

Note that the pump will stop at $p_{max.} = H_{max.} + p_{inlet}$.

$H_{max.}$ is for the pump.

If this pressure causes problems, the PM 2 can be set to stop at $p_{start} + 1$ bar, but only when installed together with an external pressure tank.

In this case, the pump is operated like a pump with a conventional pressure switch, but with additional protection of the pump, i.e. dry-running protection, cycling alarm, etc.

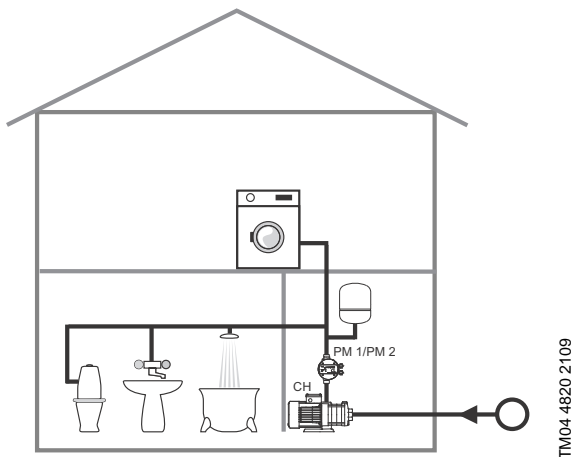

Fig. 7 Boosting of mains water pressure – only allowed in some countries

Mechanical installation

The PM 1 and PM 2 must be installed on the discharge side of the pump. The PM units can be fitted directly to the pump discharge port or between the pump and the first tapping point.

It is recommended to connect the unit to the piping system using unions.

Note: No taps must be installed between the pump and the unit.

If pumping from a well, borehole or similar, always fit a non-return valve on the suction pipe of the pump.

Location

The installation location must be clean and well ventilated.

The units must be positioned so that they are protected from rain and direct sunlight.

Height between PM unit and highest tapping point

The height (H) between the PM unit and the highest tapping point must not exceed the values in the table below.

PM type and variant	PM 1		PM 2
	1.5 bar	2.2 bar	1.5 - 5 bar
Max. height (H) between PM unit and highest tapping point	10 metres	17 metres	45 metres

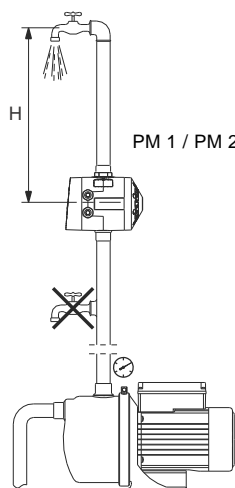

TM04 4828 2209

Fig. 8 Installation example

Electrical installation

The electrical installation must be carried out in accordance with local regulations and standards.

- The electrical installation of the PM 1 and PM 2 must be carried out so that the enclosure class is maintained.
- Make sure that the PM unit is suitable for the power supply to which it will be connected.

PM 1

The functions of the PM 1 are described below:

Anti-cycling

If there is a minor leakage in the system, or a tap has not been entirely closed, the PM 1 will start and stop the pump periodically. In order to avoid cycling, the anti-cycling function of the PM 1 will stop the pump and indicate an alarm.

Dry-running protection

The PM 1 incorporates dry-running protection that automatically stops the pump in case of dry running. The dry-running protection functions differently during priming and operation.

Note: If a dry-running alarm has been activated, the cause should be found before the pump is restarted in order to prevent damage to the pump.

Dry running during priming

If the PM 1 detects no pressure and no flow within 5 minutes after it has been connected to a power supply and the pump has started, the dry-running alarm is activated. This allows the pump to self-prime.

Dry running during operation

If the PM 1 detects no pressure and no flow within 40 seconds during normal operation, the dry-running alarm is activated.

PM 2

The PM 2 has the same functions as the PM 1, but the PM 2 has some additional functions which can be enabled and disabled with DIP switches located behind the control panel.

Auto-reset

When the auto-reset function is enabled, cycling and dry-running alarms will be automatically reset.

Note: The auto-reset function should NOT be enabled on pumps which cannot self-prime when water returns after dry-running.

Anti-cycling

To avoid inadvertent starts and stops of the pump in case of a failure in the installation, the anti-cycling function can be enabled.

The function will detect cycling if it occurs and stop the pump with an alarm.

When the PM 2 has been set to start/stop according to water consumption (default), cycling may occur in the following situations:

- In case of a minor leakage.
- If a tap has not been entirely closed.

When the PM 2 has been set to start/stop with 1 bar differential pressure, cycling may occur in the following situations:

- If the pressure tank has lost its precharge pressure.
- If the size of the pressure tank is insufficient.

If the cycling alarm has been activated, the pump can be restarted manually by pressing [Reset].

When the auto-reset function is enabled, the pump will be restarted automatically after 12 hours in alarm condition.

Note: In case of a very small consumption, the anti-cycling function may register this as a minor leakage and stop the pump inadvertently. If this occurs, the function can be disabled.

Maximum continuous operating time (30 minutes)

When this function is enabled, the pump will be stopped when the pump has been running continuously for 30 minutes.

The purpose of this function is to avoid unnecessary water and current consumption, e.g. in case of pipe fracture or considerable leakages.

Note: When the function is enabled, any consumption exceeding 30 minutes will cause an alarm, and the pump will be stopped. If enabled, the auto-reset function will not restart the pump.

Selection of Pressure Manager

The following helps determine which Pressure Manager type to select for a given application.

Functions

The PM 1 and PM 2 share some of the same functions, but the PM 2 offers some additional functions. Among other things, the start pressure for the PM 2 is adjustable.

For further information about *Functions*, see page 9.

Features

A comparison of the features of the PM 1 and PM 2 can be found in section *Features* on page 3 where the main features are also described.

Technical data

The *Technical data* for the PM 1 and PM 2 can be found on page 13. The maximum contact loads must be observed when selecting a PM 1 or PM 2. Furthermore, the height (H) between the PM unit and the highest tapping point must not exceed the values in the table below. See also fig. 8 on page 8.

PM type and variant	PM 1		PM 2
	1.5 bar	2.2 bar	1.5 - 5 bar
Max. height (H) between PM unit and highest tapping point	10 metres	17 metres	45 metres

Selection of pressure tank

Be aware that in systems where small leakages may occur, a small pressure tank might be required in order to minimise the number of starts and stops of the pump.

Recommended pressure tank:

Type	Size	Max. pressure	Pre-charge pressure	Connection	Product number
	[l]	[bar]	[bar]		
GT-H-8 V	8	10	1.5	1"	96526321

PM 1

In systems with a very small consumption, the above-mentioned pressure tank can be fitted to reduce the number of starts/stops of the pump.

PM 2

The PM 2 has an internal pressure tank with a capacity of 0.1 litre which reduces the number of starts/stops of the pump when there is a very small consumption in the system. To further reduce the number of start/stops of the pump, an external pressure tank can be installed.

Tank sizing for PM 2

The PM 2 can be set up for operation with 1 bar differential pressure, which reduces the pump operating time. When this operating mode is used, a pressure tank must be installed.

To find the correct size of the pressure tank, follow the guidelines below:

The size of the tank can be determined on the basis of the selection curves in fig. 9.

The selection curves are based on these values:

- Differential pressure $\Delta p = 1$ bar
- Number of starts/stops per hour = 20
- Precharge pressure = start pressure x 0.9 bar.

Sizing example

See fig. 9.

- Estimated consumption = 4 l/min. (point A on the x-axis)
- Start pressure = 3 bar (point B on the y-axis)
- An 18-litre pressure tank is suitable (point C).

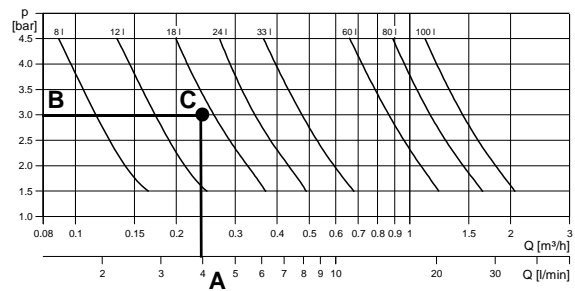

Fig. 9 Pressure tank selection curves

For further information about available tanks, see the GT data booklet available in WebCAPS. See section *Further product documentation* on page 10.

Grundfos pumps used with PM 1 and PM 2

The table below shows the Grundfos pumps which are typically used with the PM 1 or PM 2.

PM model	Max. contact load [A]		Grundfos pump type						
	230 V	115 V	CM	CH	SQ	JP	SP	SPO	CR
PM 1	6	8	•	•	•	•	•	•	•
PM 2	10	10	•	•	•	•	•	•	•

Note: The nominal motor current must not exceed the maximum contact loads of the PM units. The contact loads above refer to single-phase pumps. For use with three-phase pumps or single-phase pumps exceeding the maximum contact load, an external contactor can be used together with either PM 1 or PM 2.

Minimum discharge pressure

To ensure correct operation, the pump installed with PM 1 or PM 2 should at least be able to provide the following head:

PM type and variant	PM 1		PM 2
	1.5 bar	2.2 bar	1.5 - 5 bar
Minimum head of pump	24 metres	31 metres	19 metres

Replacement

The existing Grundfos pressure control units PRESSCONTROL[®], ECOPRESS[®], MONDIALPRESS[®] and MASCONTROL[®] can all be replaced by the PM 1 or PM 2.

PRESSCONTROL[®]

Depending on pump size (nominal motor current), the PRESSCONTROL[®] units can be replaced by either PM 1 or PM 2.

ECOPRESS[®] and MONDIALPRESS[®]

The ECOPRESS[®] and MONDIALPRESS[®] units can all be replaced by either PM 1 or PM 2.

Note that the ECOPRESS[®] and MONDIALPRESS[®] have a port-to-port length of only 150 mm whereas the PM 1 and PM 2 have a port-to-port length of 171 mm.

MASCONTROL[®]

Thanks to the low pressure loss, the MASCONTROL[®] units can be replaced by the PM 2, even if the outer dimensions of the PM 2 are smaller.

Note that the MASCONTROL[®] has 1 1/4" connections whereas the PM 2 has 1" connections.

Furthermore, the MASCONTROL[®] is rated for 2.2 kW whereas the PM 2 is rated 2.0 kW.

Replacement chart

The chart below shows the Pressure Manager unit to be used when replacing existing Grundfos PRESSCONTROL®, ECOPRESS®, MASCONTROL® and MONDIALPRESS®.

Grundfos PRESSCONTROL®, ECOPRESS®, MASCONTROL®, MONDIALPRESS® to be replaced		Grundfos Pressure Manager	
			
Type	Product number	PM 1 Product number	PM 2 Product number
PRESSCONTROL® (PC15)	465322	96848670	96848738
PRESSCONTROL® (PC15)	91217765		
PRESSCONTROL® (PC15)	465320		
PRESSCONTROL® (PC15)	465328		
PRESSCONTROL® (PC15)	91073393		
ECOPRESS® (EC15)	91535756		
ECOPRESS® (EC15)	435342		
ECOPRESS® (EC15)	465332		
MONDIALPRESS®	96630664		
MASCONTROL® (MC15)	465350		
PRESSCONTROL® (PC22)	465323		
PRESSCONTROL® (PC22)	91075043		
PRESSCONTROL® (PC22)	465331		
PRESSCONTROL® (PC22)	465321		
PRESSCONTROL® (PC22)	91217805		
ECOPRESS® (EC22)	465333		
ECOPRESS® (EC22)	465346		
MASCONTROL® (MC22)	435351		
PRESSCONTROL® (PC15)	465256	96848693	96848740
ECOPRESS® (EC15)	465336	96848722	
ECOPRESS® (EC22)	465337		
PRESSCONTROL® (PC22)	465257	96848694	
MASCONTROL® (MC15)	465354		96848728
MONDIALPRESS®	96630668	96848694	96848744
PRESSCONTROL® (PC22)	465261	96848728	96848748
PRESSCONTROL® (PC15)	465330	96848730	96848750
PRESSCONTROL® (PC15)	96439800		
ECOPRESS® (EC15)	91535757		
ECOPRESS® (EC15)	465343	96848732	
ECOPRESS® (EC22)	465347		
PRESSCONTROL® (PC22)	465329		
PRESSCONTROL® (PC22)	96439801	96848732	
MASCONTROL® (MC22)	465355		

Technical data

PM 1

Data	230 V model	115 V model
Supply voltage	1 x 220-240 VAC	1 x 110-120 VAC
Maximum inductive contact load	6 A	8 A
Frequency	50/60 Hz	
Maximum ambient temperature	See page 5	
Maximum liquid temperature	See page 5	
P _{start} ¹⁾	PM 1 - 15	1.5 bar
	PM 1 - 22	2.2 bar
Q _{min.}	1.0 litre/min.	
Time delay during stopping	10 seconds	
Maximum operating pressure	PN 10 / 10 bar / 1 MPa	
Enclosure class	IP65	
Maximum output power ²⁾	1200 W	800 W
Standby power consumption	< 1 W	
Ambient storage temperature	-30 °C to +70 °C	
Maximum humidity	95 % RH	
Maximum sound pressure level at 0-4 m ³ /h	26 dB(A)	
Net weight ³⁾	0.890 kg	

- 1) The start pressure of PM 1 (p_{start}) depends on the variant. See nameplate.
- 2) The power of PM 1 is calculated with cos φ = 0.9.
- 3) Net weight of PM 1 is the weight of the unit without cable or plug.

Note: The technical data may be limited by the pump data. See installation and operating instructions for the pump.

PM 2

Data	230 V model	115 V model
Supply voltage	1 x 220-240 VAC	1 x 110-120 VAC
Maximum inductive contact load	10 A	
Frequency	50/60 Hz	
Maximum ambient temperature	See page 5	
Maximum liquid temperature	See page 5	
P _{start} ¹⁾	1.5 to 5 bar	
P _{stop} ²⁾	P _{start} + 1 bar	
Q _{min.}	1.0 litre/min.	
Time delay during stopping	10 seconds	
Maximum operating pressure	PN 10 / 10 bar / 1 MPa	
Enclosure class	IP65	
Volume of internal pressure tank	0.1 litre	
Maximum output power ³⁾	2000 W	1000 W
Standby power consumption	< 1 W	
Ambient storage temperature	-30 °C to +70 °C	
Maximum humidity	95 % RH	
Maximum sound pressure level at 0-4 m ³ /h	26 dB(A)	
Net weight ⁴⁾	1.042 kg	

- 1) The start pressure of PM 2 (p_{start}) can be set in steps of 0.5 bar.
- 2) The stop pressure of PM 2 (p_{stop}) is only used in systems with a pressure tank.
- 3) The power of PM 2 is calculated with cos φ = 0.9.
- 4) Net weight of PM 2 is the weight of the unit without cable or plug.

Note: The technical data may be limited by the pump data. See installation and operating instructions for the pump.

Dimensions

PM 1

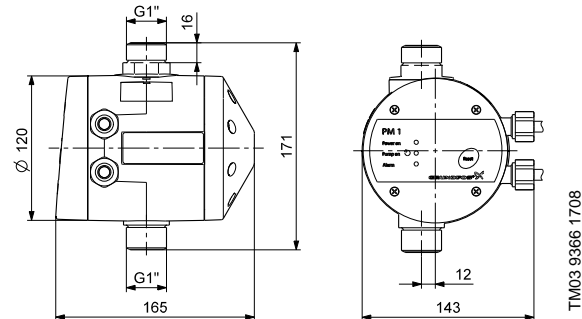

Fig. 10 Dimensional sketch of PM 1

PM 2

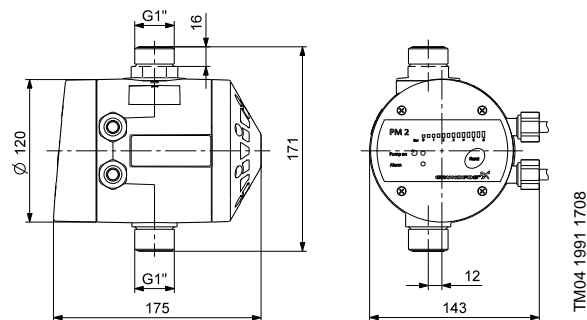

Fig. 11 Dimensional sketch of PM 2

Pressure loss curves

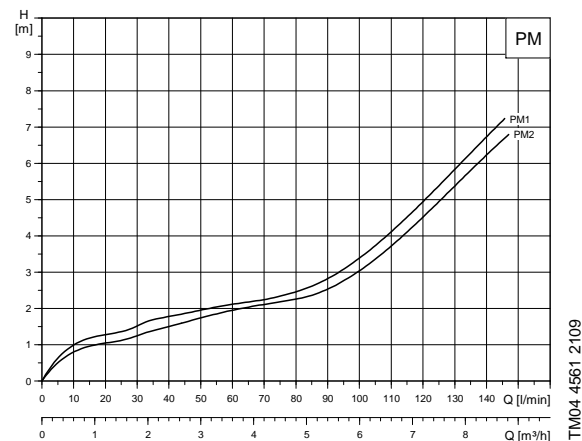

Fig. 12 Pressure loss curves for PM 1 and PM 2

Distributor: CALOR SRL
 Str. Progresului nr. 30-40, sector 5, Bucuresti
 tel: 021.411.44.44, fax: 021.411.36.14
 www.calorserv.ro - www.calor.ro